

Jennifer Newman | Ping-Pong

indoor/outdoor use

Simple, quick assembly

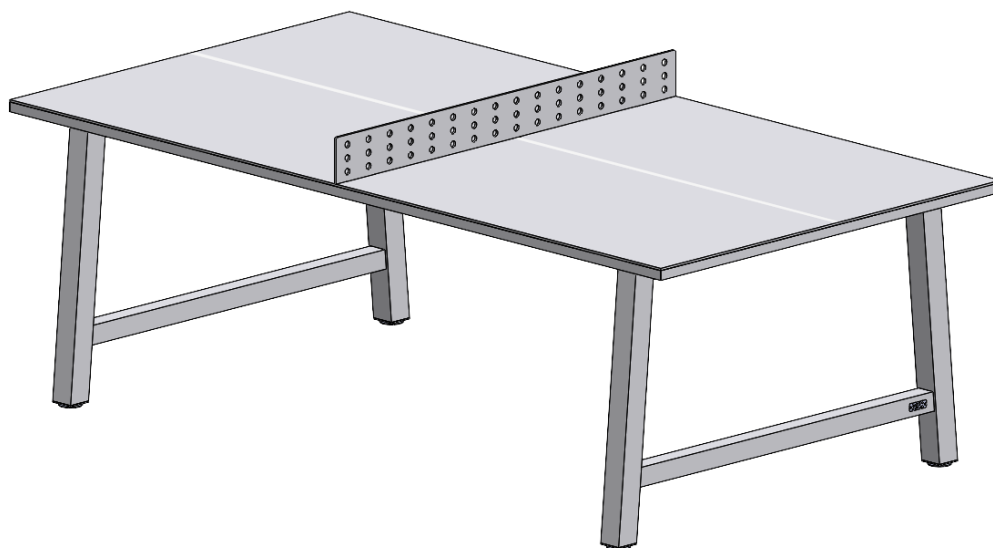

2300w x 1200d x 760h mm

Weight 80 kg

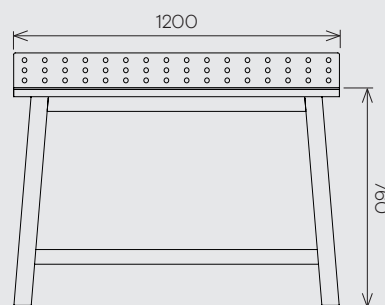
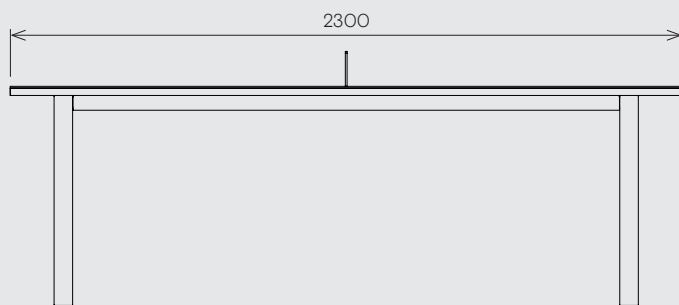

All dimensions are in mm.

- Aluminium for long-life, will not rust.
- Satin powder-coat finish.
- Anti-bacterial and Volatile-Organic-Compound free.
- Exposed aluminium central stripe.
- Removable net.
- Bolt-down brackets available.
- Minimal maintenance, easily cleaned.
- 10 standard colours, others on request (see separate reference sheet).