

Jennifer Newman | **Drum planter** indoor/outdoor use

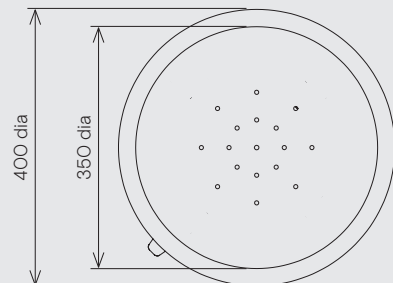

400dia x 500h mm

Weight 5 kg

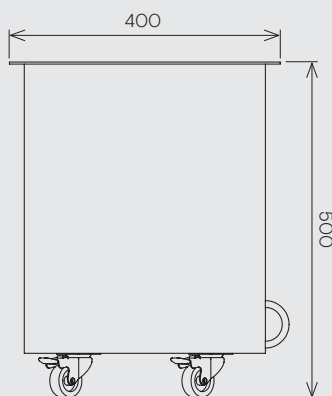

All dimensions are in mm.

- Aluminium for long-life, will not rust.
- Satin powder-coat finish.
- Anti-bacterial and Volatile-Organic-Compound free.
- Minimal maintenance, easily cleaned.
- Easy to move.
- Security hoop included.
- Lockable castors.
- Drainage holes as standard.
- Liners for indoor use not provided.
- 10 standard colours, others on request (see separate reference sheet).