

# STAK-STORE

Jennifer Newman



## Materials:

Polyester powder-coated aluminium.

## Features:

Multi-functional design. The removable top offers a planter or side-table, plus storage in the lower half.

## Warranty:

5 years provided that products are cleaned and maintained in accordance with our advice and have not been misused.

## Installation:

If used with living plants, a liner or container is required.

Dia	H (planter)	H (storage)	kg
400	650	480	5
470	750	550	8

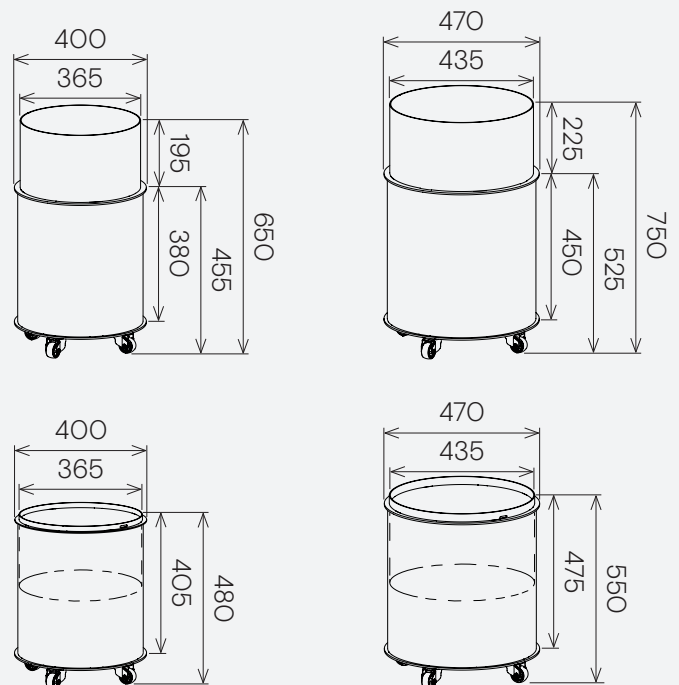

## Powder-coating standard colours

lacquer sealed



Sable  
BS 04-B-21



Oxide Red  
RAL 3009



Cream  
RAL 9001



Agate Grey  
RAL 7038



Light Blue  
BS 18-C-35



Black  
RAL 9004



Bronze



Gunmetal

email [info@jennifernewman.com](mailto:info@jennifernewman.com)

web [www.jennifernewman.com](http://www.jennifernewman.com)